



New in the range

High-tech in the smallest space.

Oil filter modules for passenger cars.



purifying our planet

What are oil filter modules?

Oil filter modules from Hengst are high-tech components with several integrated functions. The main task of the modules with integrated oil filter is to filter the abrasion particles and combustion residues from the oil and thus clean the engine oil. This is particularly important, as only clean and continuous lubrication guarantees the longevity and efficiency of an engine.

The modules are made from materials such as aluminum or special plastics to guarantee the required stability and durability. An integrated pressure relief and non-return valve ensures that the engine is supplied with oil even if the oil filter is clogged.

In addition to the oil filter, other components are included in the module, such as heat exchangers for regulating the temperature of the oil circuit or valves for controlling the cooling circuit. Other functions, such as the integration of coolant pumps and thermostats, are also possible. These multifunctional units save space in the engine compartment and reduce weight.

Our oil filter inserts, which are integrated into the module, also offer an economical and environmentally friendly solution. The Energetic® inserts from Hengst are easily replaceable and often consist of metal-free components.

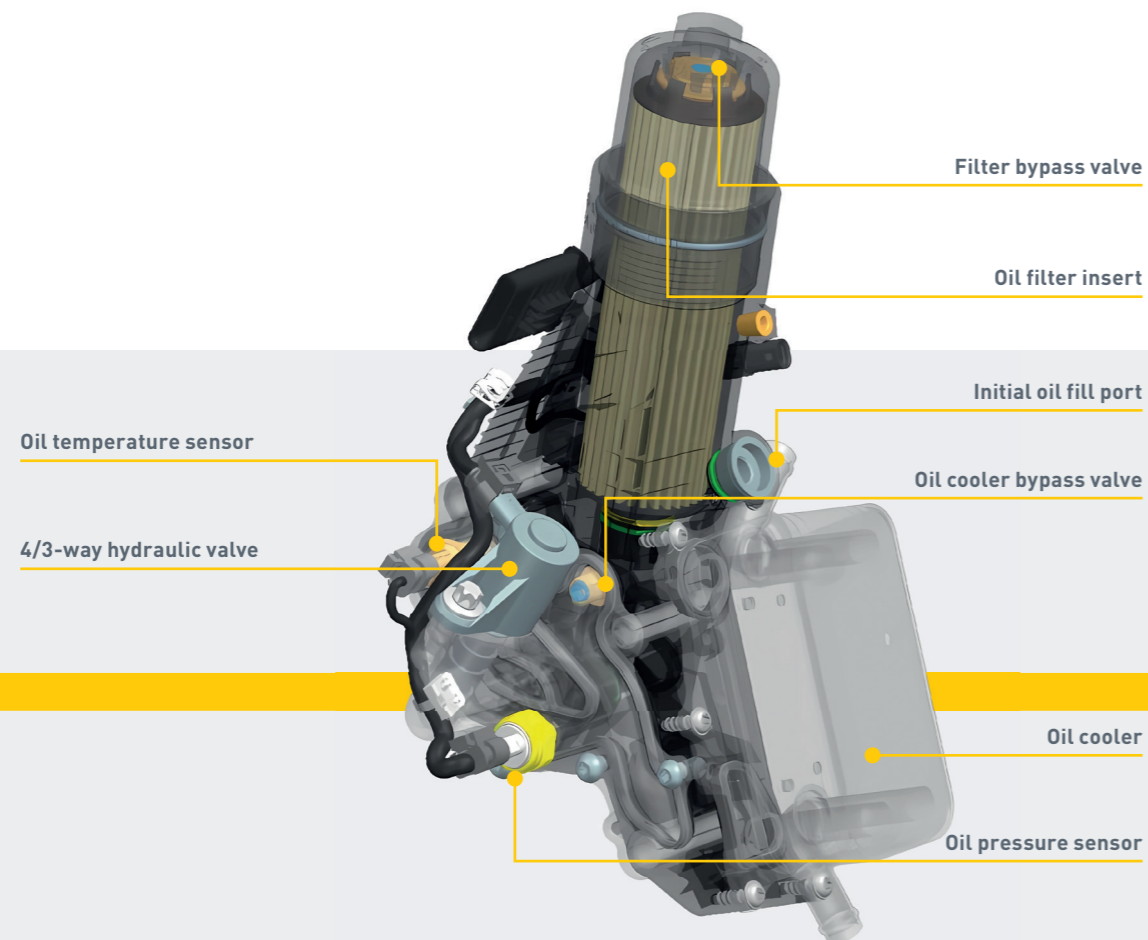

High-tech in the smallest space.

Your customer benefits at a glance:

- Mounting material, sensors and filter insert included in the scope of delivery
- Service gaskets are already pre-assembled, easy installation of the modules to facilitate assembly
- High delivery performance for all products
- In-house aluminum die casting and plastic injection molding production
- Everything from a single source for the oil circuit
- Previously only available as original equipment, now also available on the independent aftermarket
- Usual Hengst quality



Info

You will always find exactly what you need in the scope of delivery of our oil filter modules. In addition to our filter and the module itself, sensors and gaskets are also included. All in the usual Hengst quality, of course.

Defective gaskets on the original part, cracked housings, defective oil coolers, accident damage and ageing of the modules after long periods of operation - for all these problems, we recommend replacing the complete module for the best possible service.

Oil filter module for the Daimler OM 654 transverse engine

The plastic oil filter module for the OM 654 diesel engine features a heat exchanger, an integrated hydraulic directional valve, and a pressure and temperature sensor. The patented Energetic® oil filter insert guarantees optimal lubrication of the engine. Hengst offers the E159H D311 Energetic® oil filter insert to the aftermarket in OEM quality.

Overview of the Hengst oil filter module range

Available in Q4/2024

HENGST Type	GTIN Code	Application	OE number	Competition
H611H02 D928	4030776091519	Opel Astra H (A04)	12992593	Febi 182119
		Opel Insignia (G09)	25199751	Vemo V40-60-2097
		Opel Vectra (Z02)	5650364	
		Opel Zafira (A05)	93186324	
H612H D928	4030776091526	Opel Astra J (P10)	55355601	Vemo V40-60-2133
		Opel Corsa (S07)	5650365	
		Opel Meriva A (X03)	93186325	
H340H D922	4030776091557	Audi A1 (8X1, 8XK)	03N115389A	Febi 181226
		Audi A3 (8V1, 8VK)	03N115389B	Vemo V15-60-0018
		Volkswagen Golf VII (5G1, BQ1, BE1, BE2)	03N115389K	Vemo V15-60-6064
		Volkswagen Tiguan (AD1, AX1)	03N115389P	
H814H	4030776091571	Mercedes-Benz C-Class (W204, C204, S204)	A2711801010	Febi 183913
		Mercedes-Benz E-Class (W212, A207, C207)	A2711801410	Vaico V30-2890
H805H	4030776091540	Audi A1 (8XA, 8XF)	03L115389B	Febi 109394
		Audi A3 (8P1, 8P7)	03L115389C	Febi 171212
		Audi A4 B8 (8K2)	03L115389G	Vaico V10-4436
		Audi A5 (8T3)	03L115389H	Vemo V10-60-0104
H804H	4030776091533	Volkswagen Amarok (2HA, 2HB, S1B, S6B, S7A, S7B)	03L115389E	Vemo V15-60-6087
		Volkswagen Jetta IV (1K2)	03L115389J	
H815H	4030776091625	Audi A6 C7 (4G2, 4GC)	059115389H	Febi 183602
		Audi A7 Sportback (4GA, 4GF)	059115389K	Vaico V10-4622
		Audi A8 D4 (4H2, 4H8, 4HC, 4HL)	059115389P	
		Audi Q7 (4LB)		
H816H	4030776091649	Audi A6 C6 (4F2)	06F115397F	Febi 109169
		Audi TT (8J3)	06F115397H	Vaico V10-3699
		Seat Leon (1P1)	06115397J	Vemo V15-60-6080
		Skoda Octavia II (1Z3)	06F115397K	
H813H	4030776091564	Seat Cordoba (6L2)	03D115403D	Vaico V10-5792
		Skoda Fabia II (542)		
		Volkswagen Polo V (6R1, 6C1)		
H807H	4030776091601	Mercedes-Benz A-Class (W176, W177)	A2601800400	Febi 194872
		Mercedes-Benz CLA (C118)	A2701800610	Febi 194874
		Mercedes-Benz GLA-Class (X156)	A2701800810	Vemo V30-60-1353

HENGST Type	GTIN Code	Application	OE number	Competition
H812H	4030776091663	Mercedes-Benz CLC-Class (CL203)	A2721800000	Febi 179769
		Mercedes-Benz CLK (C209)	A2721800410	Vemo V30-60-1332
		Mercedes-Benz SLK (R171)	A2721800510	
H809H	4030776091618	Mercedes-Benz C-Class (S203)	A2711800610	Vaico V30-3689
		Mercedes-Benz CLK (A209)	A2711800710	
		Mercedes-Benz Sprinter (B906)	A2711880001	
H341H D925	4030776091588	Audi A4 B8 Avant (8K5)	03N115389H	Febi 194031
		Audi A5 Cabriolet (8F7)	03N115389M	Vemo V15-606098
		Audi Q5 (8RB)	03N115389R	
H341H01 D925	4030776091670	Audi A4 B9 (8W2, 8WC)	03N115389J	Vemo V15-60-6096
		Audi A5 Cabriolet (F57, F5E)	03N115389N	Vemo V15-60-6101
		Audi C7 Avant (4G5, 4GD)	03N115389S	Vemo V15-60-6103
H806H	4030776091595	BMW 116i (E81)	11427508966	Febi 188768
		BMW 316i (E46)	11427508967	Vemo V20-60-1566
		BMW X1 (E84)	11427508967S1	
H811H	4030776091656	BMW 340i (F30, F80)	11428583900	Vemo V20-60-1662
		BMW 440i (F33, F83)	11428585734	
		BMW 540i (G31)	8583895	
H810H	4030776091632	BMW 214d (F45)	11428585235	Vemo V20-60-1569
		BMW i8 (I12)		



All information without guarantee.
The table below shows an excerpt from our constantly growing range of products. For more detailed information on the above vehicle classifications and other vehicle applications, please visit our online catalog: www.hengst.com/online-catalog

Hengst is more than just a filtration specialist.

We use our expertise as an original equipment manufacturer for a wide range of product groups to also offer these in the independent aftermarket. Naturally in the usual OE quality and with the best possible service for our customers!

System:

Oil filter module

Application:

AMG M139 transverse e.g.
Mercedes-AMG A-Class

Properties:

- Compact oil filter module made of aluminum
- Horizontal construction
- Integrated heat exchanger bypass valve
- Integrated connections for coolant
- Patent-protected Energetic® oil filter system

IAM Type:

E155H01 D122

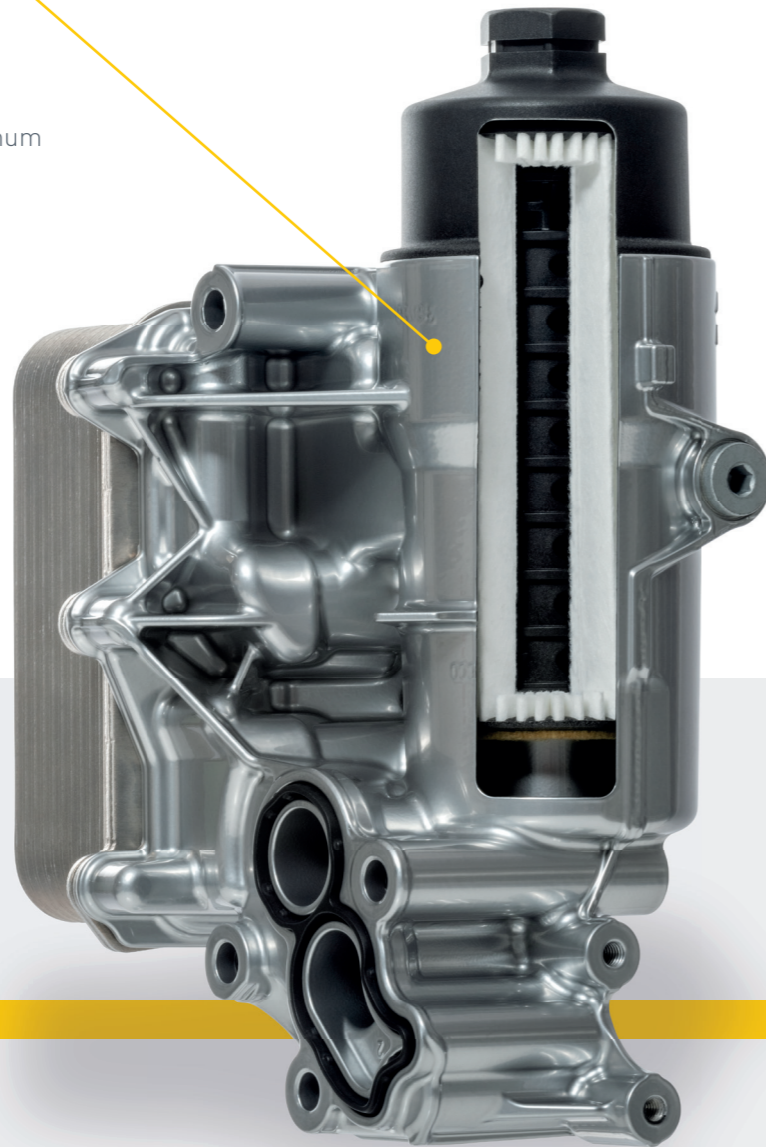

HENGST.garage

The best thing to do is to subscribe directly to the YouTube channel. Because a new, informative video goes online every two weeks!



Click here to go directly to the YouTube channel

System:

Oil filter module

Application:

Daimler OM654 transverse e.g.
Mercedes-Benz B-Class

Properties:

- Highly integrated plastic oil filter module with heat exchanger
- Heat exchangers with direct screw connection without inserts
- Integrated hydraulic directional control valve
- Integrated pressure and temperature sensor
- Patent-protected Energetic® oil filter system

IAM Type:

E159H D311

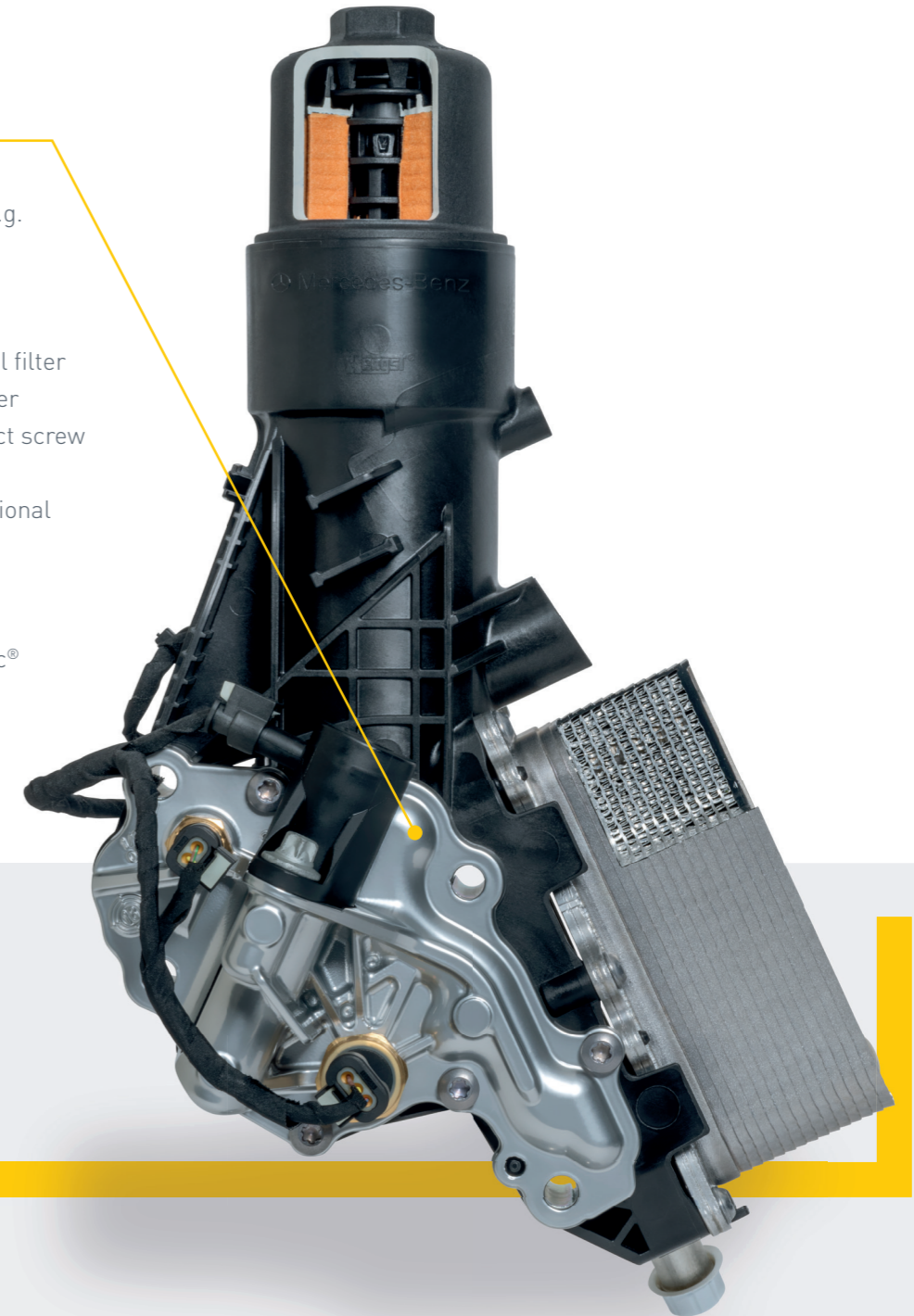

Do you have further questions or are you looking for the right spare parts? Just send an e-mail to aftermarket@hengst.com - we will be happy to contact you!



Click here to go directly to the online catalog

purifying our planet



Hengst SE

Nienkamp 55-85 | 48147 Münster | Germany
+49 251 20202-0 | aftermarket@hengst.com

hengst.com

Hengst
FILTRATION